



## **RenseWAI DP RO**

The RenseWAI DP RO Type 3 Reverse Osmosis (RO) water, directly from potable tap water.

### **Features**

- Electrical and water compartments are completely segregated, thus safer to operate.
- The Fully automated control system contains pre-rinse, RO membrane fouling preventing flush, RO membrane life detection as well as many other programs for convenient operation.
- The pre-rinsing program starts automatically when a new RO membrane is installed.
- The system is equipped with a 30-liter PE tank with a liquid level sensor.

### **Main Applications**

#### **RO Pure Water**

- Glassware cleaning
- Washing machine for glassware
- Water bath water
- Autoclave
- Feed water to laboratory animals



## Specification

### Feed Water Requirements

- Feed Water – Potable Tap Water
- Feed water conductivity < 2000  $\mu\text{S}/\text{cm}$  or TDS < 1000 ppm
- Feed water pressure – (2-6) bar
- Operating temperature – (5 – 35)  $^{\circ}\text{C}$

### Flow rate

- Type 3 RO based production rate @ 25 $^{\circ}\text{C}$ – 10, 20, 30 and 50 L/hr.

### Product Water Quality

- Type 3 or RO based water quality (@25 $^{\circ}\text{C}$ ) > 90% Ionic rejection, when compared to the feed water conductivity

### Power

- Input Voltage - 110 - 240 VAC

## Flow Chart

RenseWAI DP RO

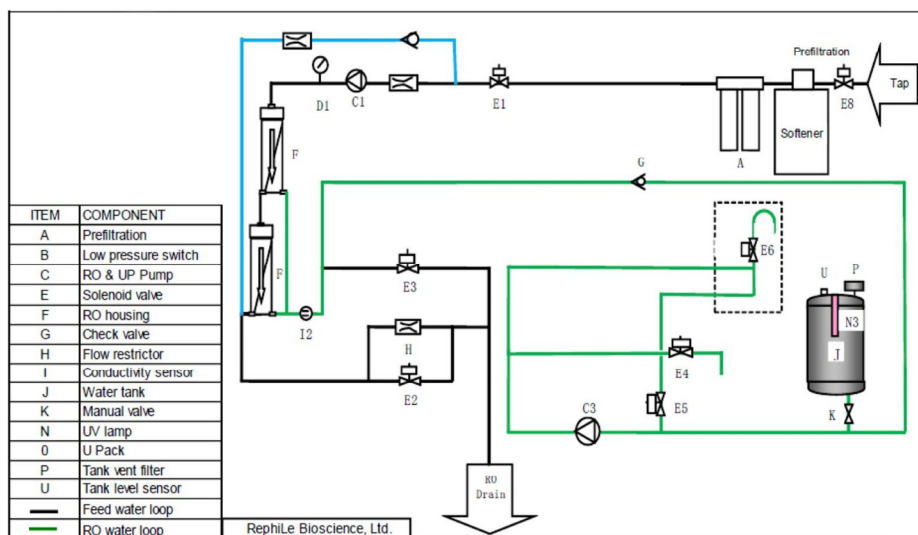

# RenseWAI

## Ordering Information

Sl.No.	Description	Catalogue No.
1	RenseWAI DP RO 10 SET	RW0R0100EK
2	RenseWAI DP RO 20 SET	RW0R0200EK
3	RenseWAI DP RO 30 SET	RW0R0300EK
4	RenseWAI DP RO 50 SET	RW0R050BEK
5	RenseWAI DP RO 10 with dispenser SET	RW0RP100EK
6	RenseWAI DP RO 20 with dispenser SET	RW0RP200EK
7	RenseWAI DP RO 30 with dispenser SET	RW0RP300EK
8	RenseWAI DP RO 50 with dispenser SET	RW0RP50BEK

## Contents of the Set

### **RenseWAI DP RO Set consists of :-**

1. Main system
2. TEKT PreFilter Stand (no cartridge)
3. TEKT cartridge
4. RO membrane (preinstalled)
5. 30 L PE water tank with level sensor
6. Tank vent filter with CO2 remover
7. Three stage prefiltration kit (PF Kit)

(1 micron + 10 micron + Carbon Cartridge of 3 micron pore size, included inside PF Kit. Quantity – 1 no. each)

8. External feed booster pump, with high & low pressure auto cutoff switch included. (Included / needed only in-case, if potable feed water pressure is less than 2 bar)

## Photographs (Representative only)



(Disclaimer – Please note photographs are for representation purpose only & can vary from the actual system)



RenseWAI is the registered trademark of M/s. Pramuk Healthcare



## RenseWAI DP RO

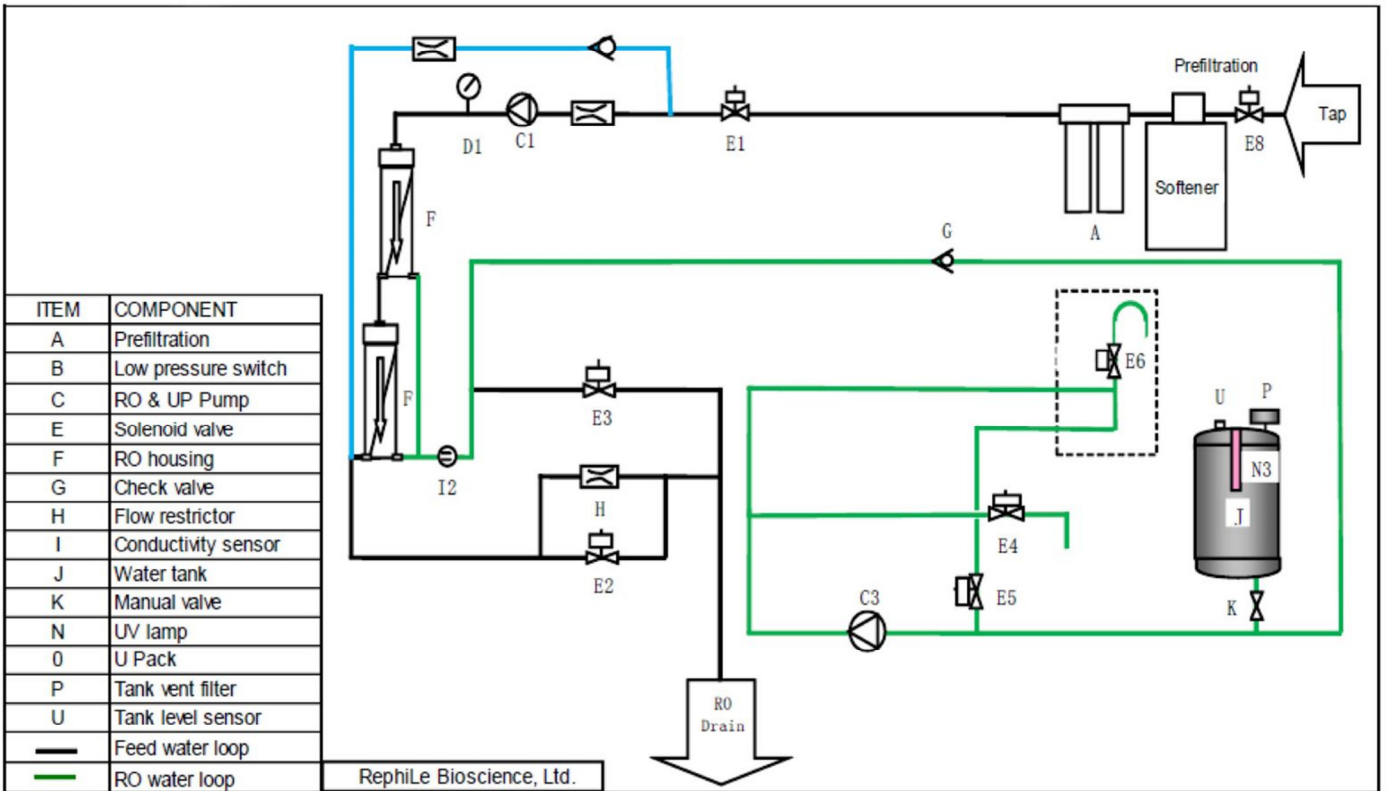

# RenseWAI

